



**FOR HIGH
Temperature**

Up to 120°C







New selection of Tecapres gas springs featuring components specifically engineered for high-temperature applications.

Designed in accordance with standard ISO & VDI dimensions

- ▶ Operating temperature up to 120°C.
- ▶ Hose system compatible.
- ▶ Full VDI safety compliance.
- ▶ Optional shield-scraper for pollution protection.
- ▶ Floating guiding system.

New Tecapres Gas Spring Range for High-Temperature Applications

Code	ØBody mm	Strokes mm	 Fa daN		 VDI SAFETY	
TPHT 300	32	10 - 125	300	✓	✓	✓
TPHT 500	38	10 - 125	500	✓	✓	✓
TPHT 750	45	10 - 125	750	✓	✓	✓
TPHT 1000	50	13 - 125	1000	✓	✓	✓
TPHTS 1000	50	160 - 300	1000	✓	✓	✓

VDI SAFETY

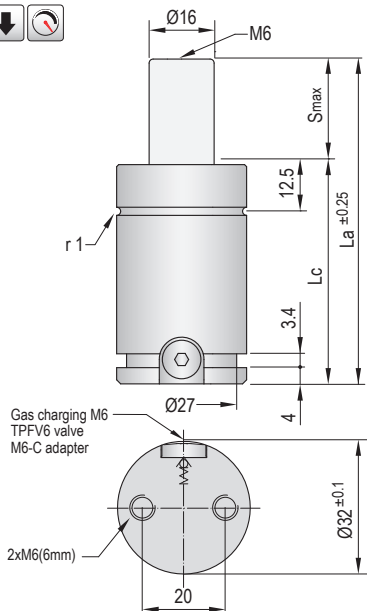

i Pressure medium	Nitrogen (N ₂)
Max. charging pressure	125 Bar
Min. charging pressure	25 Bar
Rod seal area	2,01 cm ²
Max. temperature	120°C **
Force increase by temperature	0,33 %/°C
Maintenance kit	Kit HT300
Life service	250.000 + 500.000 strokes



FOR HIGH Temperature



How to order

TPHT 300	x	75	-	120°C
Model		Stroke		Max. operating temperature
				100°C 120°C

Code	Smax mm	La mm	Lc mm	V l	Kg
TPHT 300x10	10	50	40	0,007	0,16
TPHT 300x13	13	56	43	0,008	0,17
TPHT 300x16	16	62	46	0,010	0,18
TPHT 300x19	19	68	49	0,012	0,19
TPHT 300x25	25	80	55	0,016	0,20
TPHT 300x32	32	94	62	0,020	0,22
TPHT 300x38	38	106	68	0,024	0,24
TPHT 300x50	50	130	80	0,031	0,28
TPHT 300x63	63	156	93	0,039	0,33
TPHT 300x75	75	180	105	0,046	0,36
TPHT 300x80	80	190	110	0,049	0,38
TPHT 300x100	100	230	130	0,061	0,44
TPHT 300x125	125	280	155	0,076	0,51

Operating ** temperature	Max. charging Pressure	Initial force Fa (daN)	90% End force Fc (daN)	Max. stem speed	Max. strokes/min
80°C - 100°C	125Bar (20°C)	250 (20°C)	315 (100°C)	1m/s	10+20spm
100°C - 120°C	115Bar (20°C)	230 (20°C)	305 (120°C)	0,6m/s	5+10spm

Assembly possibilities

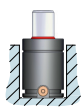

DROP-IN



SCREWS

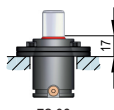

FS 32/1-FSC 32



FP 32-FPR 32

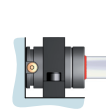

FI 32-FI 32/1

VDI SAFETY

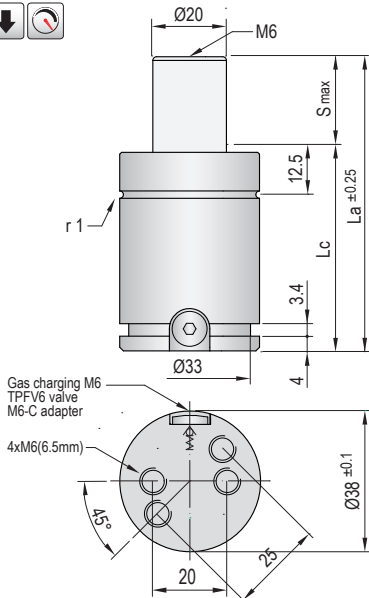

i Pressure medium	Nitrogen (N ₂)
Max. charging pressure	125 Bar
Min. charging pressure	25 Bar
Rod seal area	3,14 cm ²
Max. temperature	120°C **
Force increase by temperature	0,33 %/°C
Maintenance kit	Kit HT500
Life service	250.000 + 500.000 strokes



FOR HIGH Temperature



How to order

TPHT 500	x	50	-	100°C
Model		Stroke		Max. operating temperature
				100°C 120°C

Code	Smax mm	La mm	Lc mm	V l	Kg
TPHT 500x10	10	50	40	0,011	0,25
TPHT 500x13	13	56	43	0,014	0,26
TPHT 500x16	16	62	46	0,016	0,27
TPHT 500x19	19	68	49	0,019	0,28
TPHT 500x25	25	80	55	0,025	0,32
TPHT 500x32	32	94	62	0,031	0,34
TPHT 500x38	38	106	68	0,037	0,38
TPHT 500x50	50	130	80	0,048	0,42
TPHT 500x63	63	156	93	0,060	0,46
TPHT 500x75	75	180	105	0,072	0,50
TPHT 500x80	80	190	110	0,076	0,53
TPHT 500x100	100	230	130	0,095	0,55
TPHT 500x125	125	280	155	0,119	0,68

Operating ** temperature	Max. charging Pressure	Initial force Fa (daN)	90% End force Fc (daN)	Max. stem speed	Max. strokes/min
80°C - 100°C	125Bar (20°C)	390 (20°C)	490 (100°C)	≈ 730 (100°C)	1m/s 10÷20spm
100°C - 120°C	115Bar (20°C)	360 (20°C)	480 (120°C)	≈ 715 (120°C)	0,6m/s 5÷10spm

Assembly possibilities



Follow guidelines
Page 287

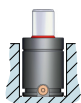

DROP-IN



SCREWS

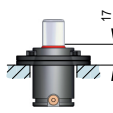

FS 38-FSC 38



FP 38-FPR 38

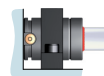

FI 38-FI 38/1

VDI SAFETY

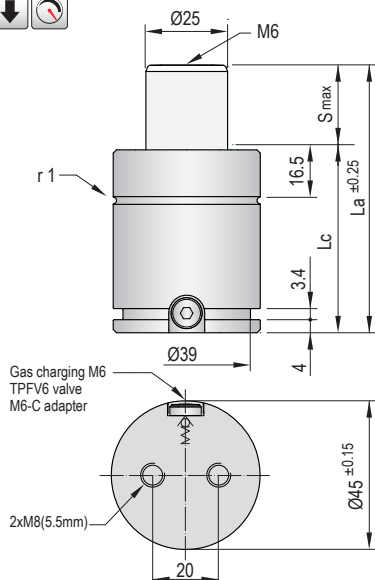

i Pressure medium	Nitrogen (N ₂)
Max. charging pressure	125 Bar
Min. charging pressure	25 Bar
Rod seal area	4,91 cm ²
Max. temperature	120°C **
Force increase by temperature	0,33 %/°C
Maintenance kit	Kit HT750
Life service	250.000 + 500.000 strokes



FOR HIGH Temperature



How to order

TPHT 750	x	25	-	100°C
Model		Stroke		Max. operating temperature
				100°C 120°C

Code	Smax mm	La mm	Lc mm	V l	Kg
TPHT 750x10	10	52	42	0,014	0,32
TPHT 750x13	13	58	45	0,018	0,35
TPHT 750x16	16	64	48	0,022	0,39
TPHT 750x19	19	70	51	0,025	0,40
TPHT 750x25	25	82	57	0,032	0,44
TPHT 750x32	32	96	64	0,041	0,47
TPHT 750x38	38	108	70	0,048	0,50
TPHT 750x50	50	132	82	0,062	0,59
TPHT 750x63	63	158	95	0,078	0,65
TPHT 750x75	75	182	107	0,092	0,80
TPHT 750x80	80	192	112	0,098	0,85
TPHT 750x100	100	232	132	0,122	0,98
TPHT 750x125	125	282	157	0,151	1,15

Operating ** temperature	Max. charging Pressure	Initial force Fa (daN)	90% End force Fc (daN)	Max. stem speed	Max. strokes/min
80°C - 100°C	125Bar (20°C)	610 (20°C) / 770 (100°C)	≈ 1270 (100°C)	1m/s	10+20spm
100°C - 120°C	115Bar (20°C)	560 (20°C) / 750 (120°C)	≈ 1240 (120°C)	0,6m/s	5+10spm

Assembly possibilities

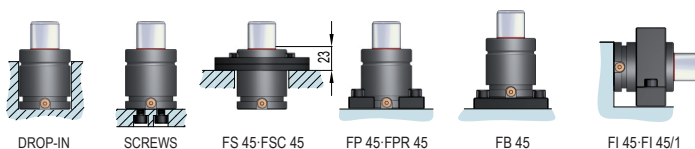

VDI SAFETY

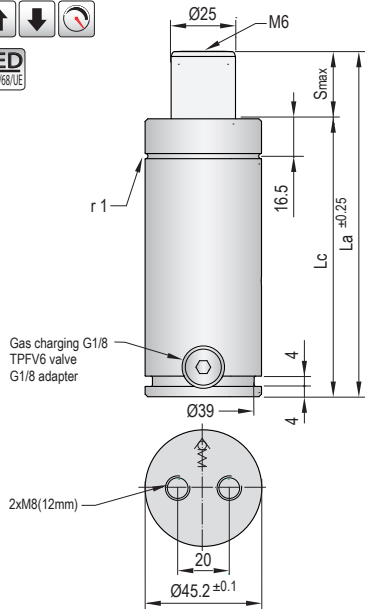

i Pressure medium	Nitrogen (N ₂)
Max. charging pressure	125 Bar
Min. charging pressure	25 Bar
Rod seal area	4,91 cm ²
Max. temperature	120°C **
Force increase by temperature	0,33 %/°C
Maintenance kit	Kit HTS750
Life service	250.000 + 500.000 strokes



FOR HIGH Temperature



How to order

TPHTS 750	x	200	-	120°C
Model	Stroke	Max. operating temperature	100°C 120°C	

Code	Smax mm	La mm	Lc mm	V l	Kg
TPHTS 750x100	100	285	185	0,121	1,60
TPHTS 750x125	125	335	210	0,150	1,70
TPHTS 750x160	160	405	245	0,163	2,20
TPHTS 750x200	200	485	285	0,202	2,35

Operating ** temperature	Max. charging Pressure	Initial force Fa (daN)	90% End force Fc (daN)	Max. stem speed	Max. strokes/min
80°C - 100°C	125Bar (20°C)	610 (20°C) 770 (100°C)	≈ 1385 (100°C)	1m/s	5÷15spm
100°C - 120°C	115Bar (20°C)	560 (20°C) 750 (120°C)	≈ 1350 (120°C)	0,6m/s	5÷10spm

Assembly possibilities



Follow guidelines
Page 287



DROP-IN



SCREWS

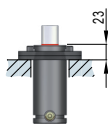

FS 45-FSC 45



FP 45-FPR 45



FB 45

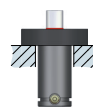

FRS 45

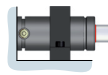

FI 45-FI 45/1

VDI SAFETY

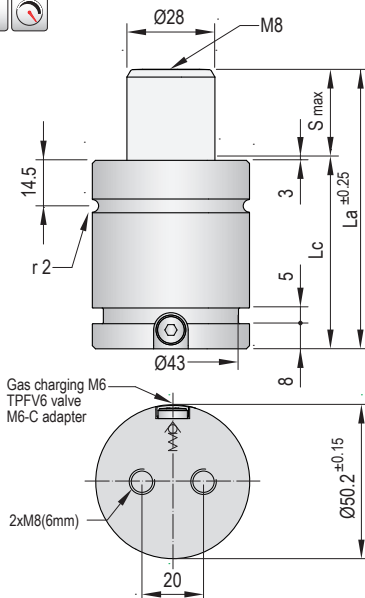

i Pressure medium	Nitrogen (N ₂)
Max. charging pressure	125 Bar
Min. charging pressure	25 Bar
Rod seal area	6,16 cm ²
Max. temperature	120°C **
Force increase by temperature	0,33 %/°C
Maintenance kit	Kit HT1000
Life service	250.000 + 500.000 strokes



FOR HIGH Temperature



How to order

TPHT 1000	x	100	-	120°C
Model		Stroke		Max. operating temperature
				100°C
				120°C

Code	Smax mm	La mm	Lc mm	V l	Kg
TPHT 1000x10	13	64	51	0,025	0,53
TPHT 1000x13	16	70	54	0,030	0,55
TPHT 1000x16	19	76	57	0,034	0,58
TPHT 1000x19	25	88	63	0,044	0,62
TPHT 1000x25	32	102	70	0,054	0,67
TPHT 1000x32	38	114	76	0,064	0,72
TPHT 1000x38	50	138	88	0,082	0,82
TPHT 1000x50	63	164	101	0,102	0,93
TPHT 1000x63	75	188	113	0,121	1,10
TPHT 1000x75	80	198	118	0,128	1,15
TPHT 1000x80	100	238	138	0,159	1,25
TPHT 1000x100	125	288	163	0,198	1,45
TPHT 1000x125	125	282	157	0,151	1,15

Operating ** temperature	Max. charging Pressure	Initial force Fa (daN)	90% End force Fc (daN)	Max. stem speed	Max. strokes/min
80°C - 100°C	125Bar (20°C)	770 (20°C)	975 (100°C)	1m/s	10÷20spm
100°C - 120°C	115Bar (20°C)	710 (20°C)	945 (120°C)	0,6m/s	5÷10spm

Assembly possibilities

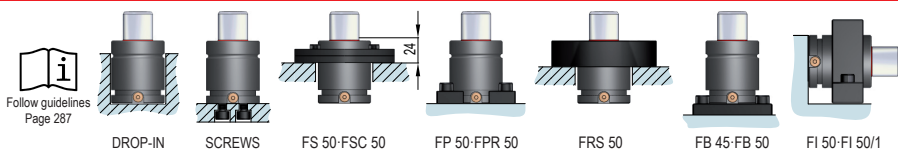

Follow guidelines Page 287

VDI SAFETY

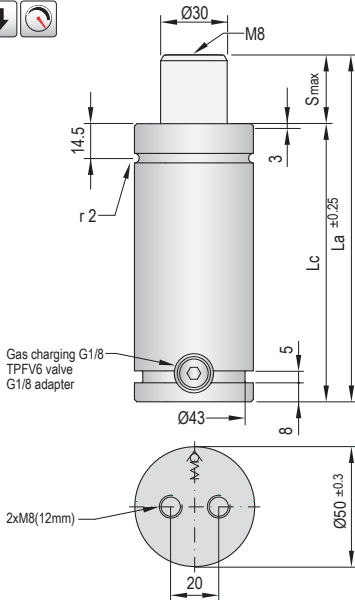

i Pressure medium	Nitrogen (N ₂)
Max. charging pressure	125 Bar
Min. charging pressure	25 Bar
Rod seal area	7,07 cm ²
Max. temperature	120°C **
Force increase by temperature	0,33 %/°C
Maintenance kit	Kit HTS1000
Life service	250.000 + 500.000 strokes



FOR HIGH Temperature

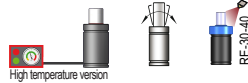

How to order

TPHTS 1000 x 160 - 100°C

Model	Stroke	Max. operating temperature	100°C 120°C
-------	--------	----------------------------	----------------

Code	Smax mm	La mm	Lc mm	V l	Kg
TPHTS 1000x160	160	415	255	0,224	2,35
TPHTS 1000x200	200	495	295	0,275	2,50
TPHTS 1000x250	250	595	345	0,337	3,25
TPHTS 1000x300	300	695	395	0,400	3,95

Operating ** temperature	Max. charging Pressure	Initial force Fa (daN)	90% End force Fc (daN)	Max. stem speed	Max. strokes/min
80°C - 100°C	125Bar (20°C)	885 (20°C)	1120 (100°C)	1m/s	5÷10spm
100°C - 120°C	115Bar (20°C)	815 (20°C)	1085 (120°C)	0,6m/s	4÷8spm

Assembly possibilities

